

UNWINDING INFORMATION

FEED FROM LEFT TO RIGHT
CRIMP IN FRONT & UPRIGHT

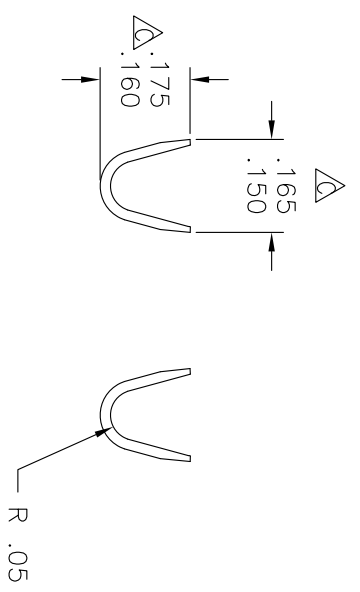

VIEW: CRIMPS

NOTE:

1.) CRITICAL DIMENSION TO BE CHECKED AS PART OF THE IN-PROCESS INSPECTION (SPC).



HEVCO PRODUCTS, INC.
TOMS RIVER, NEW JERSEY
(732) 286-4336 FAX (732) 244-8843

PART DRAWING

TOLERANCES +/-: .XX=.01 .XXX=.005 ANG.=2°	
MATL.: BRASS	FINISH:
THICK: .021	
TOOLING: DIE-A011, PUNCH-C064, ANVIL-C070	
WIRE RANGE (AWG): 18-14	
DRAWN: TMC DATE: 04/15/92	REVISED: SMH DATE: 05/31/02
APPROVED: _____	

STL-6 SPADE TERMINAL
DESCRIPTION

PART NUMBER	8140	8140-601	REVISION
			F