

1. CRITICAL DIMENSION TO BE CHECKED AS PART OF THE IN-PROCESS INSPECTION (SPC).

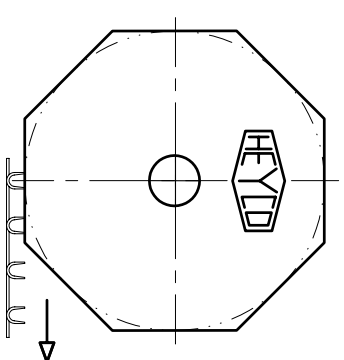
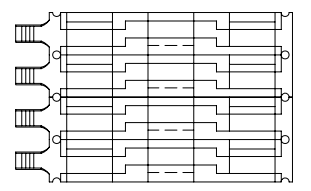

UNWINDING INFORMATION

FEED FROM LEFT TO RIGHT  
CRIMP IN FRONT & UPRIGHT

**HEYCO**  
 (732) 286-1800  
 HEYCO PRODUCTS, INC.  
 TOMS RIVER, NEW JERSEY  
 FAX (732) 244-8843

PART DRAWING

TOLERANCES +/-: .XX=.01 .XXX=.005 ANG.=28	
MATL.: 1/2 H. BRASS	FINISH:
THICK: .021	
TOOLING: PUNCH-C091, ANVL-C097	
WIRE RANGE (AWG): 18-14	
DRAWN: MS DATE: 11/01/91	APPROVED:
REVISED: MEG DATE: 08/13/01	

PCT-3B DESCRIPTION	
8084 PART NUMBER	8084-000 CATALOG NUMBER
D REVISION	