

VIEW: CRIMPS

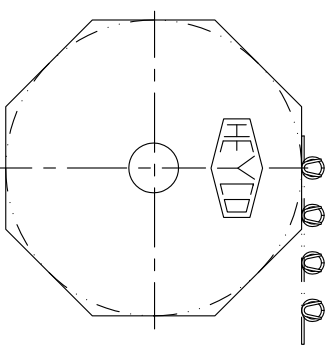
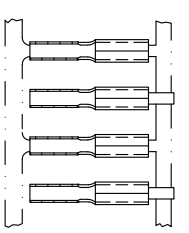
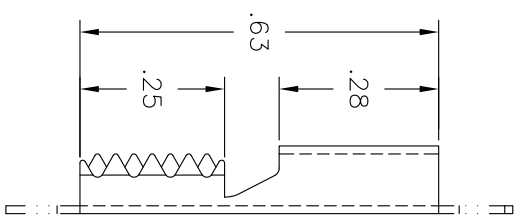
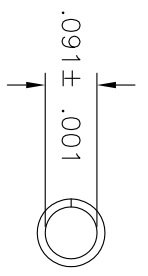

UNWINDING INFORMATION  
 FEED FROM LEFT TO RIGHT.  
 CRIMP IN FRONT & UPRIGHT.

**HEYCO**  
 HEYCO PRODUCTS, INC.  
 TOMS RIVER, NEW JERSEY  
 (732) 286-1800 FAX (732) 244-8843

PART DRAWING

TOLERANCES +/-: .XX=.01 .XXX=.005 ANG.=2°
MATL.: BRASS FINISH:
THICK: .014
TOOLING: DIE-A011, PUNCH-C449, ANVIL-C450
WIRE RANGE (AWG): 26-22
DRAWN: PJH REVISED: MEG
DATE: 3-25-92 DATE: 07/02/01
APPROVED:

SC-91-L/R

DESCRIPTION

7670	7670-001	A
PART NUMBER	CATALOG NUMBER	REVISION