

VIEW: CRIMPS

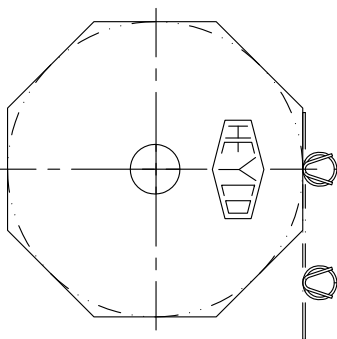
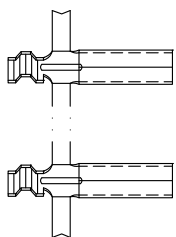

UNWINDING INFORMATION  
 FEED FROM LEFT TO RIGHT  
 CRIMP IN FRONT & UPRIGHT

**HEYCO**  
 HEYCO PRODUCTS, INC.  
 TOMS RIVER, NEW JERSEY  
 (732) 286-1800 FAX (732) 244-8843

PART DRAWING

TOLERANCES +/-: .XX=.01 .XXX=.005 ANG.=2°	
MATL.: BRASS	FINISH:
THICK: .014	
TOOLING: DIE-A011, PUNCH-C362, ANVIL-C367	
WIRE RANGE (AWG): 18-16	
DRAWN: PUH	APPROVED:
DATE: 3-24-92	DATE: 07/02/01

JH-105-8-L/R

DESCRIPTION

7535	7535-001	B
PART NUMBER	CATALOG NUMBER	REVISION