

**NOTES:**

- 1.)  CRITICAL DIMENSION TO BE CHECKED AS PART OF THE IN-PROCESS INSPECTION (SPC).

VIEW:  
INSULATION  
CRIMP

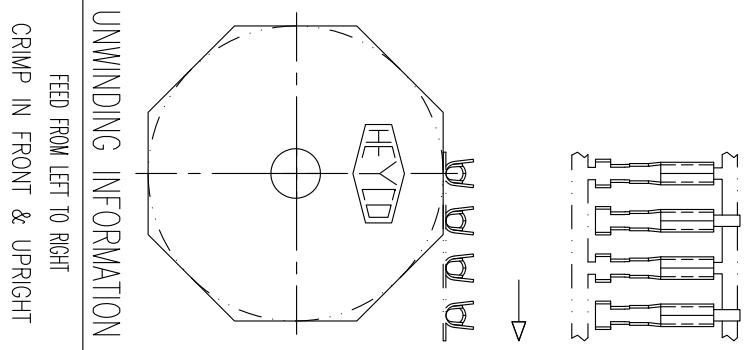
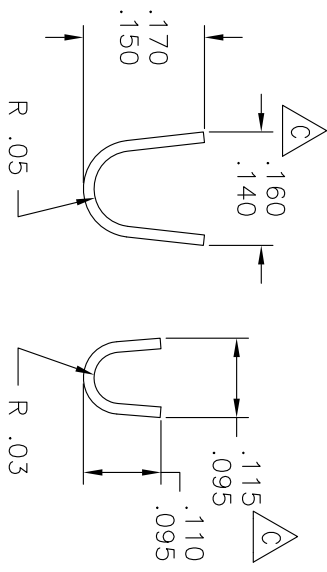

**UNWINDING INFORMATION**

FEED FROM LEFT TO RIGHT  
CRIMP IN FRONT & UPRIGHT

 **HEYCO PRODUCTS, INC.**  
TOMS RIVER, NEW JERSEY  
(732) 286-1800 FAX (732) 244-8843

**PART DRAWING**

TOLERANCES +/-:	.XX=.01	.XXX=.005	ANG.=2°
MATL.:	BRASS		
THICK:	.014		
TOOLING:	DIE-A011, PUNCH-C185, ANVIL-C189		
WIRE RANGE (AWG):	18, MAX. INS. Ø .125		
DRAWN: TJC	REVISED: MEG	APPROVED:	
DATE: 3/12/92	DATE: 06/21/01	DATE:	

FE-62-L/R  
DESCRIPTION

7386	7386-801	A
PART NUMBER	CATALOG NUMBER	REVISION