

UNWINDING INFORMATION
 FEED FROM LEFT TO RIGHT
 CRIMP IN FRONT & UPRIGHT

HEYCO
 HEYCO PRODUCTS, INC.
 TOMS RIVER, NEW JERSEY
 (732) 286-4336 FAX (732) 244-8843

PART DRAWING

TOLERANCES +/-: .XX=.01 .XXX=.005 ANG.=2°	FINISH: TINNED
MATL.: BRASS	WIRE STRIP LENGTH: .19
THICK: .025	
WIRE RANGE (AWG): 18-12	
TOOLING: UNIV. DIE-A011, PUNCH-C504, ANVIL-C510 / DIE BASE-0524, PUNCHES-06B5(16-12), 07B2(20-18), ANVILS-06B3(16-12), 07B1(20-18)	
DRAWN: PJH	REVISED: TG
DATE: 3-4-92	APPROVED: DATE:

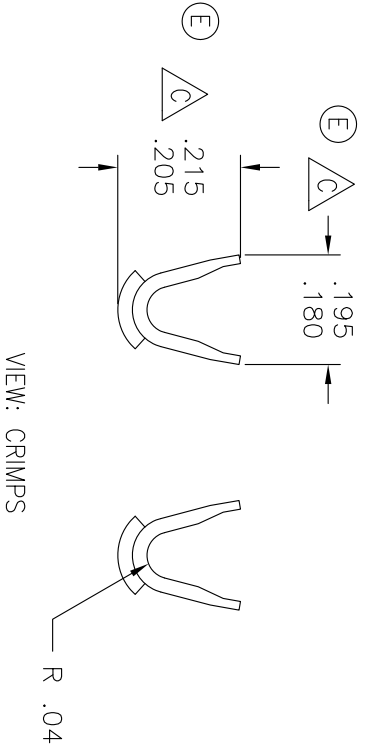

NOTE:
 1.) **C** CRITICAL DIMENSION TO BE CHECKED AS PART OF THE IN-PROCESS INSPECTION (SPC).

7274	7277-011	E
PART NUMBER	CATALOG NUMBER	REVISION
1152-TIN-L/R DESCRIPTION		