

Ⓢ MICROMETER

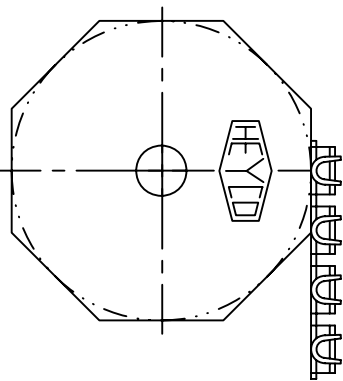
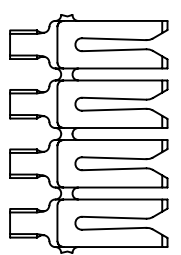

FEED FROM LEFT TO RIGHT  
CRIMP IN FRONT & UPRIGHT

**HEYCO**  
 HEYCO PRODUCTS, INC.  
 TOMS RIVER, NEW JERSEY  
 FAX (732) 244-8843  
 (732) 286-1800

PART DRAWING

TOLERANCES +/-: .XX=.01 .XXX=.005 ANG.=2°	
MATL.: BRASS FINISH:	
THICK: .028	
TOOLING: DIE-A011, PUNCH-C293, ANVIL-C302	
WIRE RANGE (AWG): 18-14	
DRAWN: TMC	REVISIONS:
DATE: 04/06/92	DATE: 07/02/01
APPROVED:	

EC60-18 .028

7225	7225-001	C
PART NUMBER	CATALOG NUMBER	REVISION

VIEW: CRIMPS

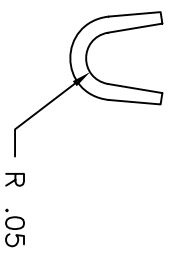
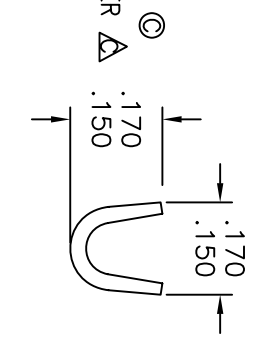

NOTES:  
 1. ⚠ CRITICAL DIMENSIONS TO BE CHECKED AS PART OF THE IN-PROCESS INSPECTION (SPC).