

NOTE:

1.) C CRITICAL DIMENSION TO BE CHECKED AS PART OF THE IN-PROCESS INSPECTION (SPC).

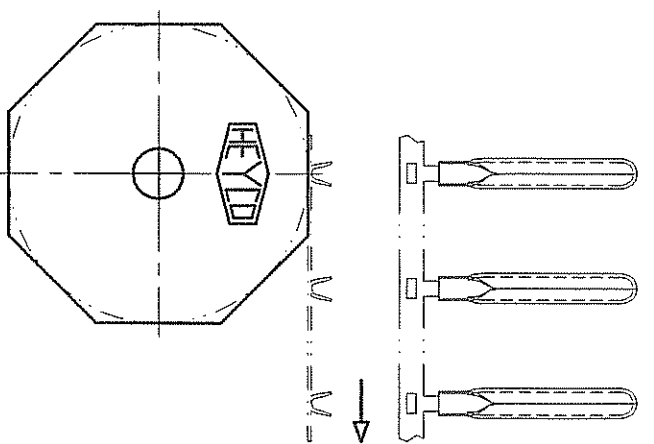

HEYCO
 HEYCO PRODUCTS, INC.
 TOMS RIVER, NEW JERSEY
 (732) 286-4336 FAX (732) 244-8843

PART DRAWING

| | |
|---|------------------------------|
| TOLERANCES +/-: .XX=.01 .XXX=.005 ANG.=2° | FINISH: |
| MATL: BRASS | THICK: .019 |
| TOOLING: DIE-A011, PUNCH-C135, ANVIL-C138 | |
| WIRE RANGE (AWG): 18-16 | |
| DRAWN: PJH DATE: 2-21-92 | REVISION: MEC DATE: 07/02/01 |
| APPROVED: <i>DC</i> | |

P-156-S-L/R

| | | |
|-------------|----------------|----------|
| 7181 | 7180-801 | D |
| PART NUMBER | CATALOG NUMBER | REVISION |