

NOTE:  
OPTIONAL CUT OFF ON  
ASSY. EQUIPMENT

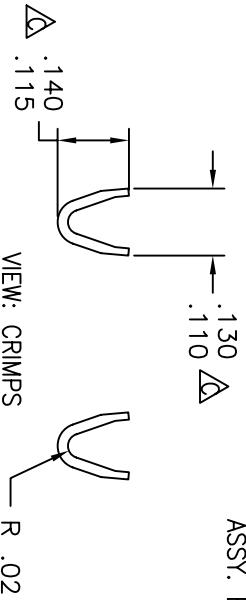

NOTE:

1.) CRITICAL DIMENSION TO BE CHECKED AS PART  
OF THE IN-PROCESS INSPECTION (SPC).

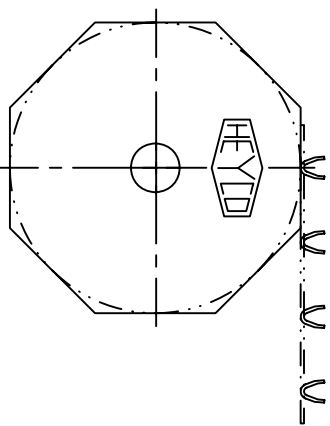

UNWINDING INFORMATION

FEED FROM LEFT TO RIGHT  
CRIMP IN FRONT & UPRIGHT

**HEYCO**  
 HEYCO PRODUCTS, INC.  
 TOMS RIVER, NEW JERSEY  
 (732) 286-1800 FAX (732) 244-8843

PART DRAWING

TOLERANCES +/-: .XX=.01 .XXX=.005 ANG.=2°	MATL.: BRASS	FINISH:
THICK: .019	WIRE STRIP LENGTH: .19	
WIRE RANGE (AWG): 18		
TOOLING: UNIV. DIE-A011, PUNCH-C229, ANVL-C231		
DIE BASE-N/A, PUNCHES-N/A, ANVLS-N/A		
DRAWN: PJC	REVISOR: MEG	APPROVED:
DATE: 2-17-92	DATE: 07/02/01	DATE:

P-93-S-L/R

DESCRIPTION

7002	7000-801	B
PART NUMBER	CATALOG NUMBER	REVISION