

VIEW: CRIMP

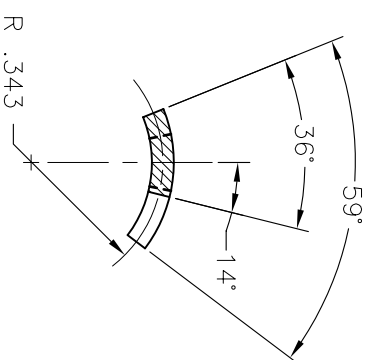

SECTION A-A

TOLERANCE UNLESS OTHERWISE SPECIFIED: .XX± 0.015 .XXX± 0.005 ANGULAR± 1.0°

MATERIAL:

BRASS

THICK: .058



HEVCO PRODUCTS, INC.
TOMS RIVER, NEW JERSEY

HEVCO PRODUCTS, INC. claims proprietary rights to the material disclosed hereon. This drawing and/or technical information is the property of HEVCO PRODUCTS, INC. It is issued in confidence for use only as authorized and may not be reproduced or described or shown to others without written permission from HEVCO PRODUCTS, INC.

DESCRIPTION

TL-ALL CONFIGURATIONS-15-W&B
18 - 14 AWG

6150

PART No.

REV.: 0