

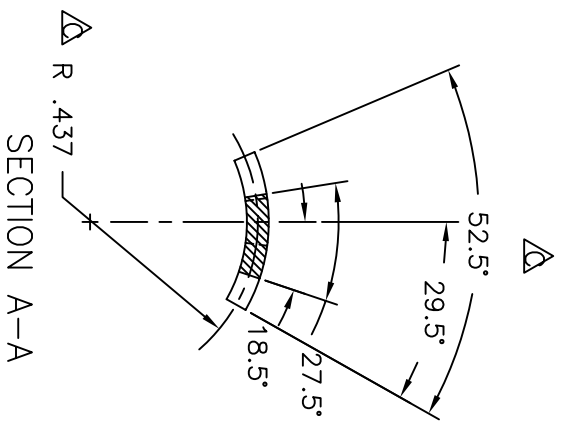

VIEW: CRIMP



SECTION A-A

- NOTES:
1. SECTION A-A DIMENSIONED TO NEMA SPEC.
 2. SEE MOLD DWG. #G-6110-0000-000 FOR RECOMMENDED LOAD BAR CONFIGURATION
 3. CRITICAL DIMENSION TO BE CHECKED AS PART OF THE IN-PROCESS INSPECTION (SPC)

HEYCO PRODUCTS, INC.
 TOMS RIVER, NEW JERSEY
 FAX (732) 244-8843
 (732) 286-1800

PART DRAWING

TOLERANCES +/-: .XX=.01 .XXX=.005 ANG.=1°			
MATL.:	BRASS	FINISH:	
THICK:	.0580		
TOOLING: DIE-A022, PUNCH-C663, ANVIL-C667			
WIRE RANGE (AWG): 16-10			
DRAWN: TMC	REVISED: MEG	APPROVED:	
DATE: 03/12/92	DATE: 6/11/01	DATE:	

TL-L5-20-B 16-10 GA.

DESCRIPTION

6116	6110-400	E
PART NUMBER	CATALOG NUMBER	REVISION