

 PIN MUST FIT GO/NOGO GAUGE.

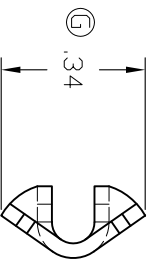
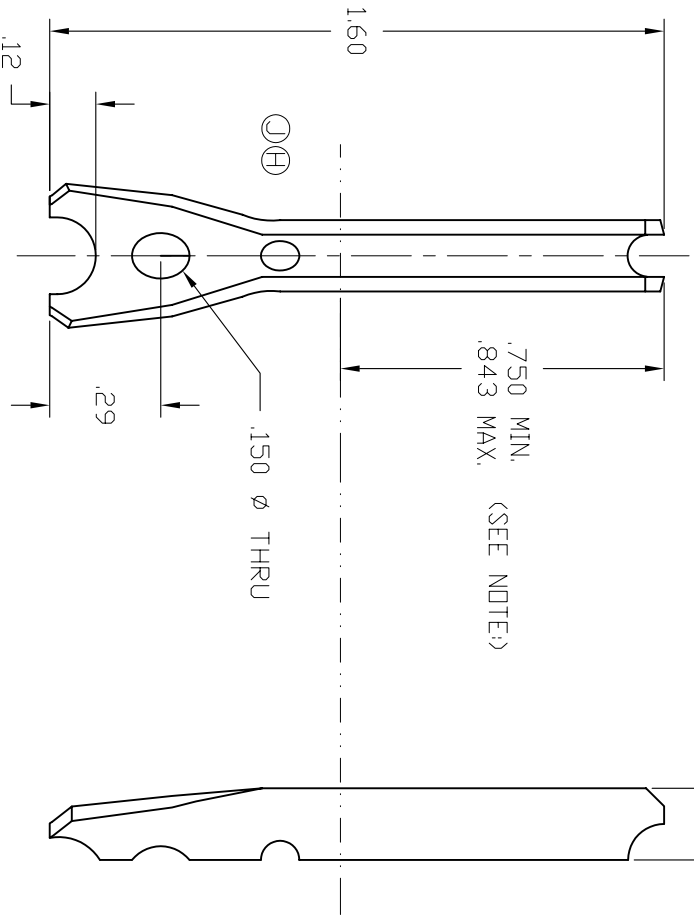
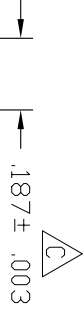
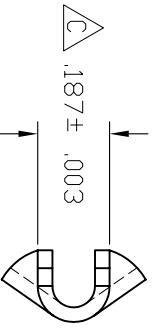

NOTES:

- 1) REFER TO PAGE 10, FIG. C1.5, UNDER UJ1681, AND CLAUSE 4.12.2 IN CSA C22.2 WHICH REFERENCES NEMA WD-16-1988.
- 2)  CRITICAL DIMENSION TO BE CHECKED AS PART OF THE IN-PROCESS INSPECTION (SPC).

TOLERANCE UNLESS OTHERWISE SPECIFIED: .XX ± .010 .XXX ± .005 ANGULAR ± 2°

MATERIAL: BRASS		 HEYCO PRODUCTS, INC. TOMS RIVER, NEW JERSEY	HEYCO PRODUCTS, INC. CATALOG DRAWING 5820-000	
FINISH:			U GROUND PIN-BULK	
THICKNESS: .038 MIN.		WIRE RANGE:		PART No.
		WIRE STRIP LENGTH: .19		REV.: J

HEYCO PRODUCTS, INC. claims proprietary rights to the material disclosed hereon. This drawing and/or technical information is the property of HEYCO PRODUCTS, INC. It is issued in confidence for use only as authorized, and may not be reproduced or described or shown to others without written permission from HEYCO PRODUCTS, INC.