

STRENGTHENING RIB:
 .04 x .11 x .004/.012 DP.

U/L & CSA
 MOLD LINE

HEYCO LOGO

UNWINDING INFORMATION

FEED FROM LEFT TO RIGHT
 CRIMP IN FRONT & UPRIGHT

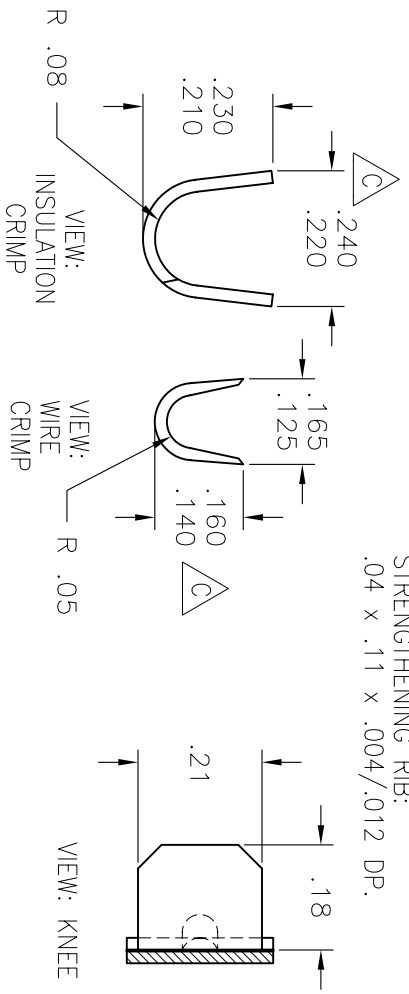
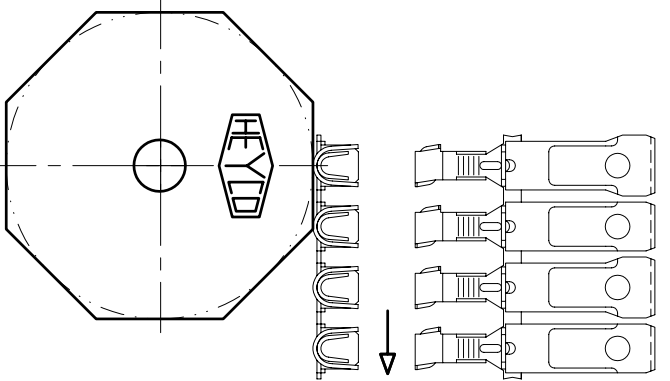

HEYCO
 HEYCO PRODUCTS, INC.
 TOMS RIVER, NEW JERSEY
 (732) 286-1800 FAX (732) 244-8843

PART DRAWING

TOLERANCES +/-: .XX=.01 .XXX=.005 ANG.=2	FINISH: TINNED
MATL.: BRASS	WIRE STRIP LENGTH: .21
THICK: .021	
WIRE RANGE (AWG): 18-14, MAX. INS. Ø .156	
TOOLING: UNV. DIE-A011, PUNCH-C294, ANVL-C302	
BELDEN APPLICATOR: PUNCH-H155, ANVL-H160	
DRAWN: TMC DATE: 08/26/91	REvised: TG DATE: 06/20/02
APPROVED: DATE:	
104-E-PAD-POL-L/R-TIN	
DESCRIPTION	
5135 PART NUMBER	5124-111 CATALOG NUMBER
D	REVISION

NOTES:
 1.) $\triangle C$ CRITICAL DIMENSION TO BE CHECKED AS PART OF THE IN-PROCESS INSPECTION (SPC).

