

Description

The B060A400AC PWM servo drive is designed to drive brushless DC motors at a high switching frequency. A single red/green LED and a single digital output indicate operating status. The drive is fully protected against over-voltage, under voltage, over-current, over-heating and short-circuits across motor, ground and power leads. Furthermore, the drive can interface with digital controllers or be used stand-alone, and requires a single unregulated AC or DC power supply and a nominal 24 VDC logic supply. Loop gain, current limit, input gain, offset, and ramp can be adjusted using 14-turn potentiometers. The offset adjusting potentiometer can also be used as an on-board input signal for testing purposes. The drive accepts quadrature encoder inputs or Hall sensor inputs for velocity control.

See Part Numbering Information on last page of datasheet for additional ordering options. The hardware installation manual for the analog drive family is available for download at www.a-m-c.com.

Power Range

Peak Current	60 A
Continuous Current	30 A
AC Supply Voltage	200 - 240 VAC
DC Supply Voltage	255 - 373 VDC



Features

- ▲ DIP Switch Selectable Current Loop Tuning
- ▲ Ramped Command Input Adjustment
- ▲ Selectable Velocity Loop Integrator Values
- ▲ Voltage Mode for Brushless Motors
- ▲ Selectable Inhibit/Enable Logic
- ▲ Selectable Fault Logic
- ▲ Selectable Tachometer Feedback Scaling
- ▲ Multiple Modes of Operation
- ▲ AC or DC Supply Input
- ▲ Built-in Shunt Regulator Circuit
- ▲ Directional Inhibit Inputs for Limit Switches
- ▲ Encoder Velocity Mode

MODES OF OPERATION

- Current
- Duty Cycle
- Voltage
- IR Comp
- Encoder Velocity
- Hall Velocity
- Tachometer

COMMAND SOURCE

- ±10 V Analog

FEEDBACK SUPPORTED

- Halls
- Incremental Encoder
- Tachometer (±60 DC)

INPUTS/OUTPUTS

- Inhibit/Enable Inputs
- Current Monitor Output
- Fault Output
- Current Reference Output
- Velocity Monitor Output
- At Velocity Output

COMPLIANCES & AGENCY APPROVALS

- UL
- cUL
- CE Class A (LVD)
- CE Class A (EMC)
- RoHS II

BLOCK DIAGRAM

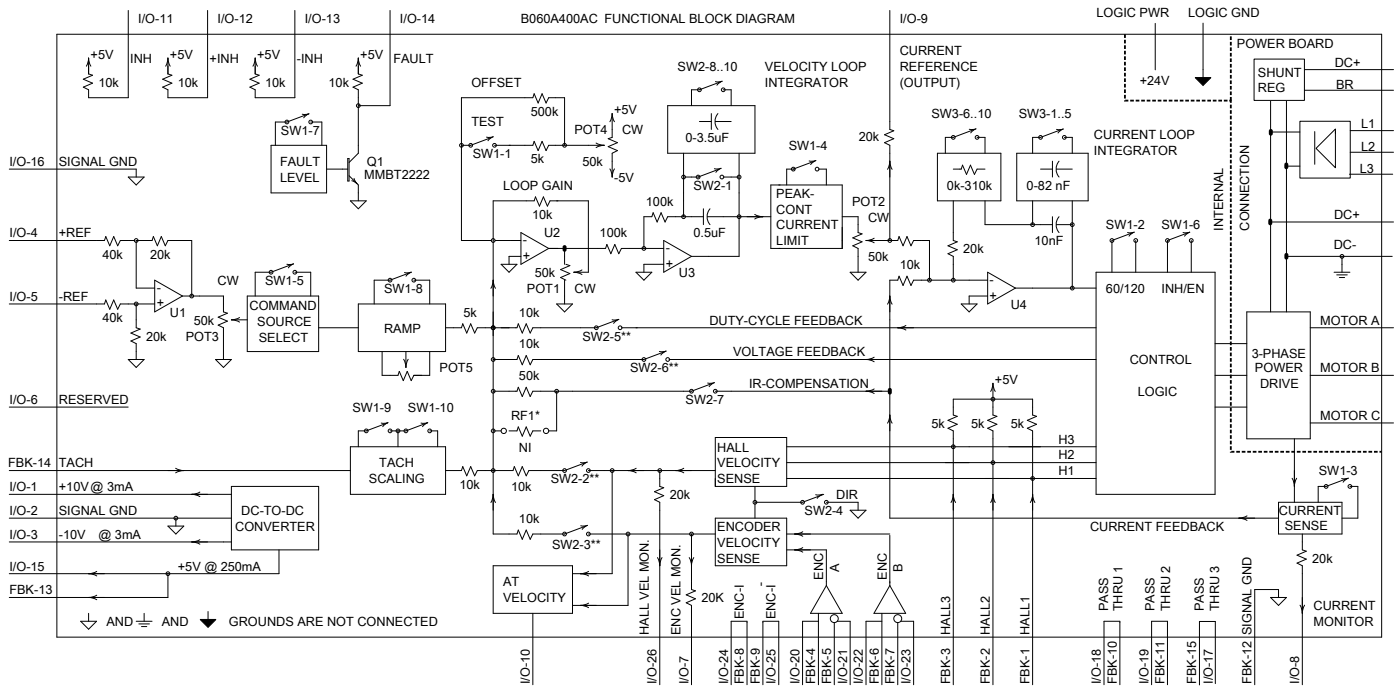

MODE SELECTIONS	SW2-1	SW2-2	SW2-3	SW2-4	SW2-5	SW2-6	SW2-7
CURRENT MODE	ON	OFF	OFF	NA	OFF	OFF	OFF
HALL VELOCITY	OFF	ON	OFF	ON/OFF	OFF	OFF	OFF
ENCODER VELOCITY	OFF	OFF	ON	ON/OFF	OFF	OFF	OFF
DUTY CYCLE MODE	OFF	OFF	OFF	NA	ON	OFF	OFF
VOLTAGE MODE	OFF	OFF	OFF	NA	OFF	ON	OFF
IR COMPENSATION	OFF	OFF	OFF	NA	OFF	ON	ON
TACHOMETER MODE	OFF	OFF	OFF	NA	OFF	OFF	OFF

LED GREEN - NORMAL OPERATION, LED RED- FAULT
 RECOMMENDED SETTING FOR CURRENT MODE - POT1 FULLY CCW, POT3 FULLY CW
 DRIVES ARE SHIPPED IN CURRENT MODE WITH MAXIMUM CURRENT SETTING
 SW2-8 MUST BE ON FOR PROPER OPERATION IN HALL VELOCITY MODE
 FOR OTHER SWITCH FUNCTIONS SEE SWITCH DESCRIPTION
 * OPTIONAL USER INSTALLED THROUGH-HOLE COMPONENT
 ** NO MORE THAN ONE SWITCH CAN BE ON.

Information on Approvals and Compliances

	<p>US and Canadian safety compliance with UL 508c, the industrial standard for power conversion electronics. UL registered under file number E140173. Note that machine components compliant with UL are considered UL registered as opposed to UL listed as would be the case for commercial products.</p>
	<p>Compliant with European EMC Directive 2004/108/EC on Electromagnetic Compatibility (specifically EN 61000-6-4:2007/A1:2011 for Emissions, Class A and EN 61000-6-2:2005 for Immunity, Performance Criteria A). LVD requirements of Directive 2006/95/EC (specifically, EN 60204-1:2006/A1:2009, a Low Voltage Directive to protect users from electrical shock).</p>
	<p>The RoHS II Directive 2011/65/EU restricts the use of certain substances including lead, mercury, cadmium, hexavalent chromium and halogenated flame retardants PBB and PBDE in electronic equipment.</p>

SPECIFICATIONS

Power Specifications		
Description	Units	Value
Rated Voltage	VAC (VDC)	240 (339)
AC Supply Voltage Range	VAC	200 - 240
AC Supply Minimum	VAC	180
AC Supply Maximum	VAC	264
AC Input Phases ¹	-	3
AC Supply Frequency	Hz	50 - 60
DC Supply Voltage Range ²	VDC	255 - 373
DC Bus Over Voltage Limit	VDC	420
DC Bus Under Voltage Limit	VDC	205
Logic Supply Voltage (Required) ³	VDC	20 - 30 (@ 850 mA)
Maximum Peak Output Current ⁴	A	60
Maximum Continuous Output Current	A	30
Max. Continuous Output Power @ Rated Voltage	W	10630
Max. Continuous Power Dissipation @ Rated Voltage	W	560
Internal Bus Capacitance	µF	1120
External Shunt Resistor Minimum Resistance ⁵	Ω	20
Internal Shunt Regulator Turn-on Voltage	VDC	399
Minimum Load Inductance (Line-To-Line) ⁶	µH	600
Switching Frequency	kHz	14
Maximum Output PWM Duty Cycle	%	100
Low Voltage Supply Outputs	-	+5 VDC (250 mA)
Control Specifications		
Description	Units	Value
Command Sources	-	±10 V Analog
Feedback Supported	-	Halls, Incremental Encoder, Tachometer (±60 VDC)
Commutation Methods	-	Trapezoidal
Modes of Operation	-	Current, Duty Cycle, Voltage, IR Comp, Hall Velocity, Encoder Velocity, Tachometer
Motors Supported	-	Single Phase (Brushed, Voice Coil, Inductive Load), Three Phase (Brushless)
Hardware Protection	-	Over Current, Over Temperature, Over Voltage, Short Circuit (Phase-Phase & Phase-Ground), Under Voltage
Internal Shunt Regulator	-	Yes
Internal Shunt Resistor	-	No
Mechanical Specifications		
Description	Units	Value
Agency Approvals	-	CE Class A (EMC), CE Class A (LVD), cUL, RoHS II, UL
Size (H x W x D)	mm (in)	256.5 x 182.6 x 83.7 (10.1 x 7.2 x 3.3)
Weight	g (oz)	2821.3 (99.5)
Heatsink (Base) Temperature Range ⁷	°C (°F)	0 - 75 (32 - 167)
Storage Temperature Range	°C (°F)	-40 - 85 (-40 - 185)
Form Factor	-	Panel Mount
Cooling System	-	Natural Convection
FEEDBACK Connector	-	15-pin, high-density, female D-sub
I/O Connector	-	26-pin, high-density, female D-sub
LOGIC POWER Connector	-	2-port, 5.08 mm spaced, enclosed, friction lock header
FAN Connector	-	2-port, 5.08 mm spaced, enclosed, friction lock header
MOTOR POWER Connector	-	4-port, 10.16 mm spaced, enclosed, friction lock header
DC POWER Connector	-	4-port, 10.16 mm spaced, enclosed, friction lock header
AC POWER Connector	-	4-port, 10.16 mm spaced, enclosed, friction lock header

Notes

- Can operate on single-phase AC (208 VAC minimum) as long as output power does not exceed 3kW maximum.
- Large inrush current may occur upon initial DC supply connection to DC Bus.
- Additional current is required if an external fan is used with the Fan Connector. Required total current will be 850mA + [required fan mA].
- Capable of supplying drive rated peak current for 2 seconds with 3 second foldback to continuous value. Longer times are possible with lower current limits.
- ADVANCED Motion Controls recommends using an external fuse in series with an external shunt resistor. A 5 amp time delay fuse is typical.
- Lower inductance is acceptable for bus voltages well below maximum. Use external inductance to meet requirements.
- Additional cooling and/or heatsink may be required to achieve rated performance.

PIN FUNCTIONS

I/O Signal Connector			
Pin	Name	Description / Notes	I/O
1	+10V OUT	+10V @ 3 mA. For customer use.	O
2	SGN GND	Signal Ground	SGND
3	-10V OUT	-10V @ 3 mA. For customer use.	O
4	+REF	Differential reference input, maximum 15V, 40k input resistance.	I
5	-REF		I
6	RESERVED	Reserved	-
7	ENCODER VELOCITY MONITOR	Encoder Velocity Monitor. Analog output proportional to the frequency of the encoder lines or, equivalently, to motor speed. Scaling is 25 kHz/V.	O
8	CURRENT MONITOR	This output represents the actual motor current. Scaling: SW1-3 = OFF, 1V = 10 A motor current SW1-3 = ON, 1V = 20 A motor current	O
9	CURRENT REFERENCE	This is the command signal to the internal current-loop. The maximum peak current rating of the drive always equals 7.24 V at this pin.	O
10	AT VELOCITY	Open Collector output. Internally pulled up to 5V through 10k. This output is low when the speed is within 10% of the commanded speed. Encoder or Hall Velocity is selectable through DIP Switch settings.	O
11	INHIBIT/ENABLE	This TTL level input signal turns off all power devices of the "H" bridge when pulled to ground with SW1-6=ON. Operates from 3.3V to 24V. If SW1-6=OFF, pulling this pin to ground will enable the drive.	I
12	+INHIBIT/ENABLE	If SW1-6=ON, ground pin 12 to inhibit (+) drive output and pin 13 to inhibit (-) drive output. If SW1-6=OFF, ground pin 12 to enable (+) drive output and pin 13 to enable (-) drive output. These inputs will NOT cause a fault condition or a red LED. Operates from 3.3V to 24V.	I
13	-INHIBIT/ENABLE		I
14	FAULT OUT	This output activates during short circuit, over-voltage, under voltage, inhibit, over-temperature and power-on reset. A red LED also indicates a fault condition. Active high or active low selectable through SW1-7.	O
15	+5V OUT (Common with FBK-13)	+5V @ 250mA. For customer use. Note that the total current on Feedback Connector Pin 13 and this pin should not exceed 250mA.	O
16	SGN GND (Common with FBK-12)	Signal Ground	SGND
17	PASS-THROUGH	Connected to Feedback Connector Pin 15.	-
18	PASS-THROUGH	Connected to Feedback Connector Pin 10.	-
19	PASS-THROUGH	Connected to Feedback Connector Pin 11.	-
20	ENCODER A+ OUT (Common with FBK-4)	Differential Encoder Output from Feedback Connector Pin 4	O
21	ENCODER A- OUT (Common with FBK-5)	Differential Encoder Output from Feedback Connector Pin 5	O
22	ENCODER B+ OUT (Common with FBK-6)	Differential Encoder Output from Feedback Connector Pin 6	O
23	ENCODER B- OUT (Common with FBK-7)	Differential Encoder Output from Feedback Connector Pin 7	O
24	ENCODER I+ OUT (Common with FBK-8)	Differential Encoder Output from Feedback Connector Pin 8	O
25	ENCODER I- OUT (Common with FBK-9)	Differential Encoder Output from Feedback Connector Pin 9	O
26	HALL VELOCITY MONITOR	Hall Velocity Monitor. Analog output proportional to the Hall frequency or, equivalently, to motor speed. Scaling is 100 Hz/V.	O

Feedback Connector			
Pin	Name	Description / Notes	I/O
1	HALL 1	Hall sensor inputs, internal 2K pull-up. Logic levels: maximum low level input is 1.5 VDC, minimum high level input is 3.5 VDC.	I
2	HALL 2		I
3	HALL 3		I
4	ENCODER A+ IN (Common with I/O-20)	Differential Encoder Input, Channel A	I
5	ENCODER A- IN (Common with I/O-21)		I
6	ENCODER B+ IN (Common with I/O-22)	Differential Encoder Input, Channel B	I
7	ENCODER B- IN (Common with I/O-23)		I
8	ENCODER I+ IN (Common with I/O-24)	Differential Encoder Input, Index Mark (Not Required)	I
9	ENCODER I- IN (Common with I/O-25)		I
10	PASS-THROUGH	Connected to I/O Connector Pin 18	-
11	PASS-THROUGH	Connected to I/O Connector Pin 19	-
12	SGN GND (Common with I/O-16)	Signal Ground	SGND
13	+5V OUT (Common with I/O-15)	+5V @ 250mA. For customer use. Note that the total current on I/O Connector Pin 15 and this pin should not exceed 250mA.	O
14	TACH IN	Tachometer Input, 60k ohm input resistance, ± 60 V max. (Scalable with SW1-9,10)	I
15	PASS-THROUGH	Connected to I/O Connector Pin 17	-

Logic Power Connector			
Pin	Name	Description / Notes	I/O
1	LOGIC GND	Logic Supply Ground	LGND
2	LOGIC PWR	Logic Supply Input. Required for drive operation.	I

Fan Power Connector

Pin	Name	Description / Notes	I/O
1	FAN GND	Fan Ground (Common with Logic Ground)	LGND
2	FAN PWR	Fan Power Output	O

Motor Power Connector

Pin	Name	Description / Notes	I/O
1	CHASSIS	Chassis Ground	CGND
2	MOTOR A	Motor Phase A	O
3	MOTOR B	Motor Phase B	O
4	MOTOR C	Motor Phase C	O

DC Power Connector

Pin	Name	Description / Notes	I/O
1	DC-	Power Ground	PGND
2	DC+	DC Power Input	I
3	DC+	External Shunt Resistor Connection. Connect resistor between DC+ and BR.	I
4	BR		-

AC Power Connector

Pin	Name	Description / Notes	I/O
1	L1	AC Supply Input (Three Phase). External 20 A time delay fuses are recommended in series with the AC input lines.	I
2	L2		I
3	L3		I
4	CHASSIS	Chassis Ground	CGND

HARDWARE SETTINGS

Switch Functions

SW-1	Description	Setting	
		On	Off
1-1	Test / Offset controls the sensitivity of the “offset” pot. This is used as an on-board reference signal in test mode.	Test	Offset
1-2	120/60 degree commutation phasing.	120 degree phasing	60 degree phasing
1-3	Current scaling. When OFF, this increases the sensitivity of the current sense thus reducing both peak and continuous current limit by 50%.	100%	50%
1-4	Continuous current reduction.	Continuous / peak current limit ratio is 50%	Continuous / peak current limit ratio is 25%
1-5	Reserved	-	-
1-6	Inhibit / Enable	Ground I/O Connector pins 11, 12, 13 to inhibit motor outputs	Ground I/O Connector pins 11, 12, 13 to enable motor outputs
1-7	Active Fault Level of P1-14.	Active HIGH	Active LOW
1-8	Ramped Command	Enable Ramping	Disable Ramping
1-9	Tachometer Input Scaling Switches. These switches adjust the value of the allowed maximum tachometer input voltage.	See Tachometer Input Scaling Table below.	
1-10			

Tachometer Input Scaling Table

DIP Switches SW1-9 and SW1-10 are used to set the Maximum Tachometer Input Voltage value according to the following table.

±V	SW1-9	SW1-10
10	ON	ON
26	OFF	ON
43	ON	OFF
60	OFF	OFF

Current Limit Adjustments

These amplifiers feature separate peak and continuous current limit adjustments. The current limit adjustment Pot 2 adjusts both peak and continuous current limit at the same time. Pot 2 has 12 active turns and one inactive turn on each end and is approximately linear. Thus, to adjust the current limit turn the potentiometer counter-clockwise to zero, then turn clockwise to the appropriate value. In many applications it is sufficient to use only the DIP-switches for current limit adjustments. SW1-3 reduces both peak and continuous current limit by 50% when OFF. SW1-4 reduces only the continuous current limit by 50% when OFF:

SW1-4	CONTINUOUS / PEAK CURRENT LIMIT RATIO
ON	50%
OFF	25%

I/O Connector Pin 9 is the input to the internal current amplifier power stage. Since the output current is proportional to I/O Connector Pin 9, the adjusted current limit can easily be observed at this pin without connecting the motor. Note that a command signal must be applied to the reference inputs to obtain a reading on I/O Connector Pin 9. The maximum peak current value equals 7.24 V at this pin and the maximum continuous current value equals 3.62 V at this pin. If SW1-3=ON, peak rated amplifier current = 7.24 V. If SW1-3=OFF, ½ peak rated amplifier current = 7.24 V.

The actual output current can be monitored at I/O Connector Pin 8.

SW-2	Description	Setting	
		On	Off
2-1	Mode Selection. See Mode Selection Table below for full description of mode switch settings.	Current Mode	Velocity Modes
2-2	Hall Velocity feedback. This connects the internally generated velocity signal from the Hall sensors.	Hall sensor velocity feedback enabled.	Hall sensor velocity feedback disabled.
2-3	Encoder Velocity feedback. This connects the internally generated velocity signal from the encoder.	Encoder velocity feedback enabled.	Encoder velocity feedback disabled.
2-4	Velocity Feedback Polarity	Toggles the polarity of the velocity feedback signal (Encoder or Hall velocity mode only).	
2-5	Duty Cycle feedback. This connects the internally generated velocity signal from the output stage.	Duty cycle feedback enabled.	Duty cycle feedback disabled.
2-6	Voltage Mode.	Voltage feedback enabled.	Voltage feedback disabled.
2-7	IR Compensation Mode.	IR Comp enabled.	IR Comp disabled.
2-8	Velocity Loop Integrator Capacitor Switches. These adjust the value of the integrator capacitor in the velocity mode.	See Velocity Loop Integrator Capacitance Table below.	
2-9			
2-10			

*Important Note: Drive will not operate properly with more than one of these switches ON due to multiple feedback signals.

Mode Selection Table

Operating modes can be selected by setting SW2 DIP switches according to the following table.

	SW2-1	SW2-2	SW2-3	SW2-4	SW2-5	SW2-6	SW2-7
CURRENT	ON	OFF	OFF	X	OFF	X	OFF
DUTY CYCLE	OFF	OFF	OFF	X	ON	X	OFF
VOLTAGE	OFF	OFF	OFF	X	OFF	ON	OFF
IR COMP	OFF	OFF	OFF	X	OFF	ON	ON
HALL VELOCITY	OFF	ON	OFF	X	OFF	ON	OFF
ENCODER VELOCITY	OFF	OFF	ON	X	OFF	X	OFF
TACHOMETER	OFF	OFF	OFF	X	OFF	X	OFF

X = does not affect mode

Velocity Loop Integrator Capacitance Table

Set the Velocity Loop Integrator Capacitance value according to the following table. Decreasing the capacitance increases the integrator gain.

μF	SW2-8	SW2-9	SW2-10
0.5	OFF	OFF	OFF
1.0	ON	OFF	OFF
1.5	OFF	ON	OFF
2.0	ON	ON	OFF
2.5	OFF	OFF	ON
3.0	ON	OFF	ON
3.5	OFF	ON	ON
4.0	ON	ON	ON

Current Loop Tuning Values

SW3 DIP switches add additional resistance and capacitance to the current loop tuning circuitry. SW3 switches 1-5 add additional parallel capacitance to the current loop integrator capacitor, and SW3 switches 6-10 add additional series resistance to the current loop gain resistor (see Block Diagram). Capacitance and resistance values are given in the tables below along with the appropriate DIP switch settings.

SW3																	
Switch	Additional Current Loop Integrator Capacitance (μF) – (decreasing the capacitance increases the integrator gain)																
	SHORT	.082	.077	.072	.067	.062	.057	.052	.047	.035	.030	.025	.020	.015	.010	.005	OPEN
1	ON	ON	OFF	ON	OFF	ON	OFF	ON	OFF	ON	OFF	ON	OFF	ON	OFF	ON	OFF
2	ON	ON	ON	OFF	OFF	ON	ON	OFF	OFF	ON	ON	OFF	OFF	ON	ON	OFF	OFF
3	ON	ON	ON	ON	ON	OFF	OFF	OFF	OFF	ON	ON	ON	ON	OFF	OFF	OFF	OFF
4	ON	ON	ON	ON	ON	ON	ON	ON	ON	OFF	OFF	OFF	OFF	OFF	OFF	OFF	OFF
5	ON	OFF	OFF	OFF	OFF	OFF	OFF	OFF	OFF	OFF	OFF	OFF	OFF	OFF	OFF	OFF	OFF

SW3																	
Switch	Additional Current Loop Gain Resistance (kΩ) – (increasing the resistance increases the proportional gain)																
	0	10	20	30	40	50	60	70	80	90	100	110	120	130	140	150	
6	ON	OFF	ON	OFF	ON	OFF	ON	OFF	ON	OFF	ON	OFF	ON	OFF	ON	OFF	
7	ON	ON	OFF	OFF	ON	ON	OFF	OFF	ON	ON	OFF	OFF	ON	ON	OFF	OFF	
8	ON	ON	ON	ON	OFF	OFF	OFF	OFF	ON	ON	ON	ON	OFF	OFF	OFF	OFF	
9	ON	ON	ON	ON	ON	ON	ON	ON	OFF	OFF	OFF	OFF	OFF	OFF	OFF	OFF	
10	ON	ON	ON	ON	ON	ON	ON	ON	ON	ON	ON	ON	ON	ON	ON	ON	
Switch (continued)	160	170	180	190	200	210	220	230	240	250	260	270	280	290	300	310	
6	ON	OFF	ON	OFF	ON	OFF	ON	OFF	ON	OFF	ON	OFF	ON	OFF	ON	OFF	
7	ON	ON	OFF	OFF	ON	ON	OFF	OFF	ON	ON	OFF	OFF	ON	ON	OFF	OFF	
8	ON	ON	ON	ON	OFF	OFF	OFF	OFF	ON	ON	ON	ON	OFF	OFF	OFF	OFF	
9	ON	ON	ON	ON	ON	ON	ON	ON	OFF	OFF	OFF	OFF	OFF	OFF	OFF	OFF	
10	OFF	OFF	OFF	OFF	OFF	OFF	OFF	OFF	OFF	OFF	OFF	OFF	OFF	OFF	OFF	OFF	

Potentiometer Functions

Potentiometer	Description	Turning CW
Pot 1	Loop gain adjustment in open loop and velocity modes. Turn this pot fully CCW in current mode.	Increases loop gain
Pot 2	Current limit. Adjusts both the continuous and peak current limit while maintaining the continuous/peak ratio set by the DIP Switches.	Increases current limit
Pot 3	Reference in gain. This potentiometer adjusts the ratio between input signal and output variables (voltage, current, and velocity).	Increases reference input gain
Pot 4	Test/Offset. Used to adjust any imbalance in the input signal or in the drive. When SW1-1 (DIP switch) is ON, the sensitivity of this pot is greatly increased allowing it to be used as an on-board signal source for testing purposes.	Zero speed setting is at the midpoint of this 14-turn pot.
Pot 5	Ramp Time. Sets the ramp time for the command input signal.	Increases ramp time (slower Accel or Decel)

Note: Potentiometers are approximately linear and have 12 active turns with 1 inactive turn on each end.

Ramping Command (Pot 5):

The built-in ramp circuit allows the command input to be ramped linearly. This feature is activated by setting SW1-8 = ON. The ramp time can be set for up to 30 seconds in reaching the max command by adjusting Pot 5 fully clockwise. Ramping rates are linear with respect to time and apply to both directions of motion. For example, if the single-ended command input is only 2.5 Volts, the time to ramp to this voltage would be half the time to ramp to 5 Volts.

Through-hole Components[†]

Location	Description
RF1	IR Compensation Scaling. Through-hole resistor that can be added to configure the amplifier for IR Compensation mode. See section below on IR Compensation Notes for more details.

IR Compensation Notes

For applications that will use IR Compensation mode, a resistor can be added to the location named in the table above. The combination of the added resistor and correct DIP switch settings will configure the amplifier for IR Compensation mode. While in IR Compensation mode, the amplifier will adjust the duty cycle to compensate for changes in the output current. Consult the amplifier's functional block diagram and the manufacturer's website for more information.

[†]NOTE: DAMAGE DONE TO THE DRIVE WHILE PERFORMING THESE MODIFICATIONS WILL VOID THE WARRANTY.

MECHANICAL INFORMATION

Feedback Connector

Connector Information		15-pin, high-density, female D-sub
Mating Connector	Details	TYCO: Plug P/N 748364-1; Housing P/N 5748677-1; Terminals P/N 1658670-2 (loose) or 1658670-1 (strip)
	Included with Drive	No

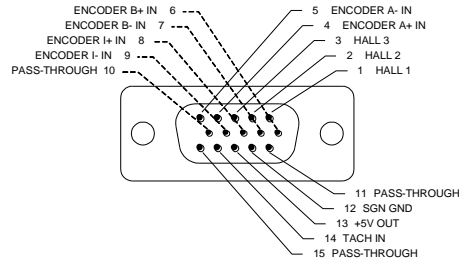

I/O Signal Connector

Connector Information		26-pin, high-density, female D-sub
Mating Connector	Details	TYCO: Plug P/N 1658671-1; Housing P/N 5748677-2; Terminals P/N 1658670-2 (loose) or 1658670-1 (strip)
	Included with Drive	No

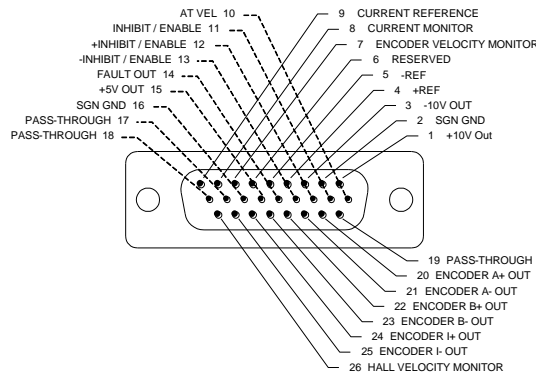

Logic Power Connector

Connector Information		2-pin, 5.08 mm spaced, enclosed, friction lock header
Mating Connector	Details	Phoenix Contact: P/N 1757019
	Included with Drive	Yes

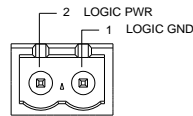

Fan Power Connector

Connector Information		2-port, 5.08 mm spaced, enclosed, friction lock header
Mating Connector	Details	Phoenix Contact: P/N 1757019
	Included with Drive	No

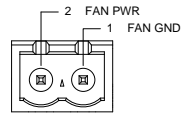

Motor Power Connector

Connector Information		4-pin, 10.16 mm spaced, enclosed, friction lock header
Mating Connector	Details	Phoenix Contact: P/N 1913523
	Included with Drive	Yes

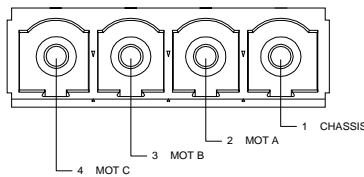

DC Power Connector

Connector Information		4-pin, 10.16 mm spaced, enclosed, friction lock header
Mating Connector	Details	Phoenix Contact: P/N 1913523
	Included with Drive	Yes

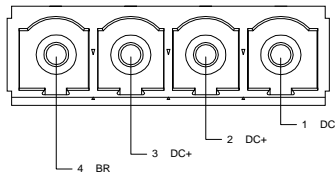

AC Power Connector

Connector Information		4-pin, 10.16 mm spaced, enclosed, friction lock header
Mating Connector	Details	Phoenix Contact: P/N 1913523
	Included with Drive	Yes

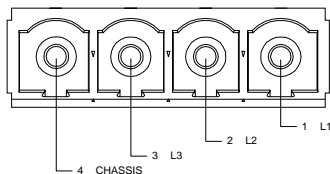

MOUNTING DIMENSIONS

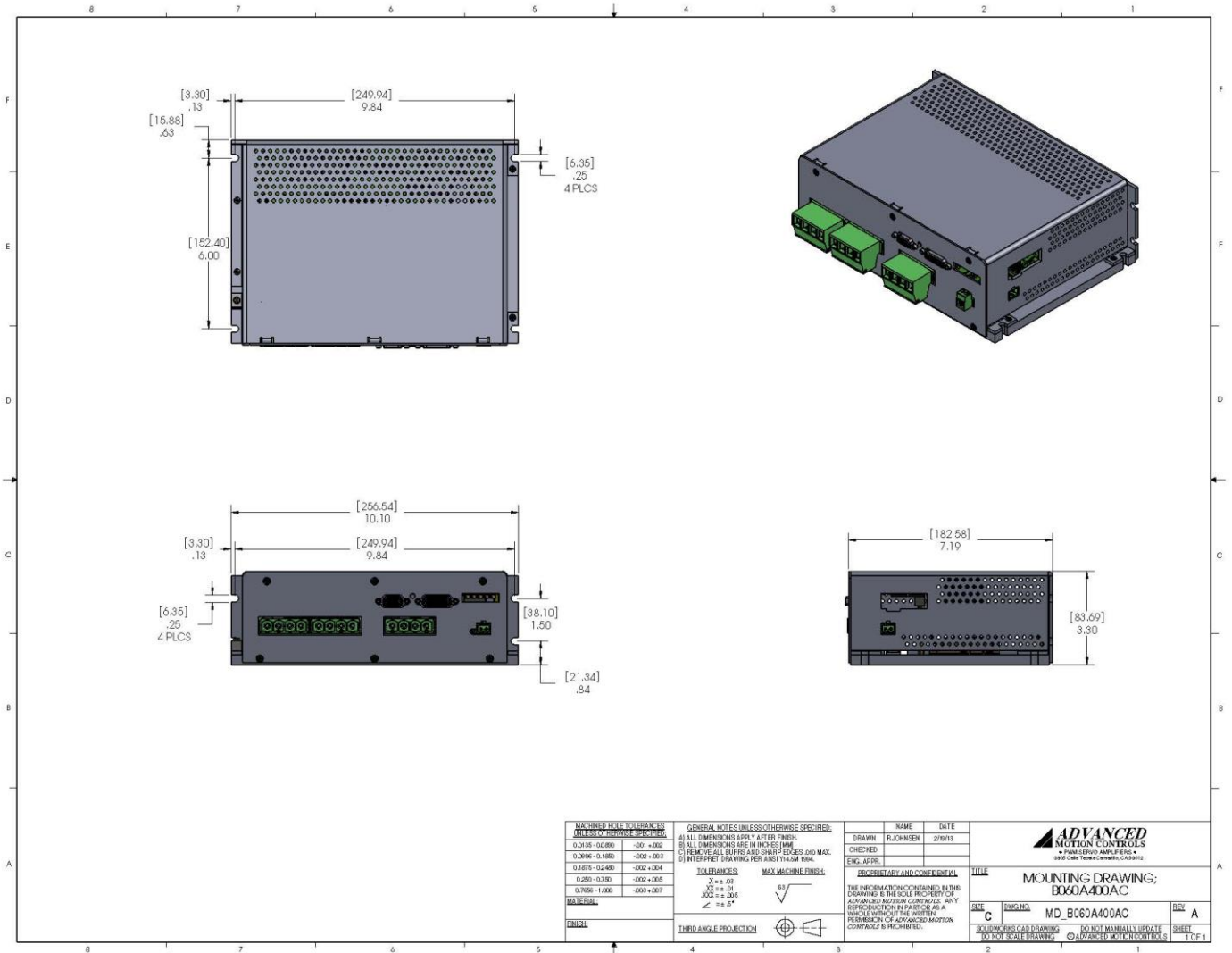

MACHINED HOLE TOLERANCES (UNLESS OTHERWISE SPECIFIED)		GENERAL NOTES (UNLESS OTHERWISE SPECIFIED):		NAME	DATE
0.0150 - 0.0400	-.001 +.002	A) ALL DIMENSIONS APPLY AFTER FINISH		DRAWN	RJOHNSON
0.0400 - 0.1800	-.002 +.003	B) ALL DIMENSIONS ARE IN INCHES UNR		CHECKED	
0.1875 - 0.2400	-.002 +.004	C) REMOVE ALL BURRS AND SHARP EDGES AND MAX.		ENG. APPR.	
0.250 - 0.750	-.002 +.005	D) INTERPRET DRAWING PER ANSI Y14.5M 1994.			
0.7500 - 1.000	-.003 +.007				
MATERIAL		TOLERANCES	MAX MACHINABLE FINISH	PROPERTY AND CONFIDENTIAL	
FINISH		X ± .03		TITLE	
		Y ± .01		MOUNTING DRAWING;	
		Z ± .005		B060A400AC	
		∠ ± 6°		SIZE	MD_B060A400AC
				DRG. NO.	
				REV	A
				SHEET	1 OF 1

PART NUMBERING INFORMATION

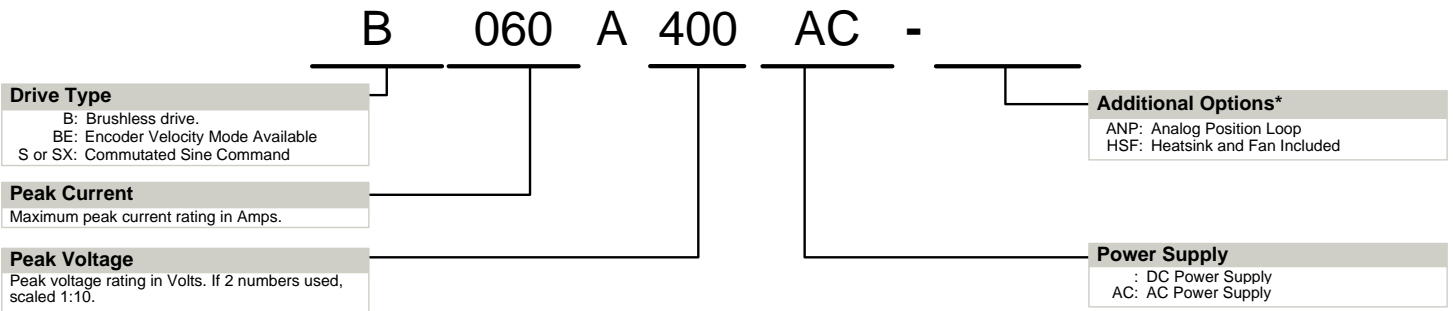

* Options available for orders with sufficient volume. Contact *ADVANCED* Motion Controls for more information.

ADVANCED Motion Controls analog series of servo drives are available in many configurations. Note that not all possible part number combinations are offered as standard drives. All models listed in the selection tables of the website are readily available, standard product offerings.

ADVANCED Motion Controls also has the capability to promptly develop and deliver specified products for OEMs with volume requests. Our Applications and Engineering Departments will work closely with your design team through all stages of development in order to provide the best servo drive solution for your system. Equipped with on-site manufacturing for quick-turn customs capabilities, *ADVANCED* Motion Controls utilizes our years of engineering and manufacturing expertise to decrease your costs and time-to-market while increasing system quality and reliability. Feel free to contact Applications Engineering for further information and details.

Examples of Modifications and Customized Products

- | | |
|---|--|
| <ul style="list-style-type: none"> ▲ Integration of Drive into Motor Housing ▲ Mount OEM PCB onto Drive Without Cables ▲ Multi-axis Configuration for Compact System ▲ Custom PCB and Baseplate for Optimized Footprint ▲ RTV/Epoxy Components for High Vibration ▲ OEM Specified Connectors for Instant Compatibility ▲ OEM Specified Silkscreen for Custom Appearance ▲ Increased Thermal Limits for High Temp. Operation | <ul style="list-style-type: none"> ▲ Integrate OEM Circuitry onto Drive PCB ▲ Custom Control Loop Tuned to Motor Characteristics ▲ Custom I/O Interface for System Compatibility ▲ Preset Switches and Pots to Reduce User Setup ▲ Optimized Switching Frequency ▲ Ramped Velocity Command for Smooth Acceleration ▲ Remove Unused Features to Reduce OEM Cost ▲ Application Specific Current and Voltage Limits |
|---|--|

Available Accessories

ADVANCED Motion Controls offers a variety of accessories designed to facilitate drive integration into a servo system. Visit www.a-m-c.com to see which accessories will assist with your application design and implementation.



All specifications in this document are subject to change without written notice. Actual product may differ from pictures provided in this document.