

TBM Series 3-Way Ball Valve

Operating, Installation, & Maintenance Manual

*Corrosion Resistant Fluid and
Air Handling Systems.*

SIMTECH

TBM Series Ball Valves

Operating, Installation, and Maintenance Instructions

SIMTECH RECOMMENDS READING THE FOLLOWING INFORMATION PRIOR TO INSTALLING AND USING OUR VALVES, STRAINERS, CONTROLS AND OTHER ASSOCIATED PRODUCTS. FAILURE TO FOLLOW THESE INSTRUCTIONS MAY RESULT IN SERIOUS INJURY.

1. Simtech guarantees its products against defective material and workmanship only. Simtech assumes no responsibility for damage or injuries resulting from improper installation, misapplication, or abuse of any product.
2. Simtech assumes no responsibility for damage or injury resulting from chemical incompatibility between its products and the process fluids to which they are subjected. Compatibility charts provided in Simtech literature are based on ambient temperatures of 70F and are for reference only. Customer should always test to determine application suitability.
3. Consult Simtech literature to determine operating pressure and temperature limitations before installing any Simtech product. Note that the maximum recommended fluid velocity through any Simtech product is eight feet per second. Higher flow rates can result in possible damage due to the water hammer effect. Also note that maximum operating pressure is dependent upon material selection as well as operating temperature.
4. Simtech products are designed primarily for use with non-compressible liquids. They should NEVER be used or tested with compressible fluids such as compressed air or nitrogen.
5. Systems should always be depressurized and drained prior to installing or maintaining Simtech products.
6. Temperature effect on piping systems should always be considered when the systems are initially designed. Piping systems must be designed and supported to prevent excess mechanical loading on Simtech equipment due to system misalignment, weight, shock, vibration, and the effects of thermal expansion and contraction.
7. Because PVC and CPVC plastic products become brittle below 40F, Simtech recommends caution in their installation and use below this temperature.
8. Published operating torque requirements are based upon testing of new valves using clean water at 70F. Valve torque is affected by many factors including fluid chemistry, viscosity, flow rate, and temperature. These should be considered when sizing electric or pneumatic actuators.
9. Due to differential thermal expansion rates between metal and plastic, transmittal of pipe vibration, and pipe loading forces **DIRECT INSTALLATION OF METAL PIPE INTO PLASTIC CONNECTIONS IS NOT RECOMMENDED**. Wherever installation of plastic valves into metal piping systems is necessary, it is recommended that at least 10 pipe diameter in length of plastic pipe be installed upstream and downstream of the plastic valve to compensate for the factors mentioned above.

TBM Series Ball Valves

Operating, Installation, and Maintenance Instructions

SOCKET CONNECTION:

Socket end connections are manufactured to ASTM D2467-94. Solvent cementing of socket end connections to pipe should be performed per ASTM specifications D2855-87. Cut pipe square. Chamfer and deburr pipe. Surfaces must be cleaned and free of dirt, moisture, oil and other foreign material. Remove assembly nuts and end connectors from valve body. Slide assembly nuts, with threads facing valve, onto pipe to which the end connector is to be cemented. Apply primer to inside socket surface of end connector. Never allow primer or cement to contact valve ball or end connector o-ring sealing surfaces, as leaking may result. Use a scrubbing motion. Repeat applications may be necessary to soften the surface of the socket. Next, liberally apply primer to the male end of the pipe to the length of the socket depth. Again apply to the socket, without delays apply cement to the pipe while the surface is still wet with primer. Next apply cement lightly, but uniformly to the inside of the socket. Apply a second coat of cement to the pipe, and assemble the end connector to the pipe, rotating the end connector 1/4 turn in one direction as it is slipped to full depth on to the pipe. The end connector should be held in position for approx. 30 seconds to allow the connection to "set". After assembly wipe off excess cement. Full set time is a minimum of 30 minutes at 60 to 100 F. Full cure time should be based on the chart below.

THREADED CONNECTION:

Threaded end connections are manufactured to ASTM specifications D2464-88, F437-88 and ANSI B2.1. Wrap threads of pipe with Teflon tape of 3 to 3-1/2 mil thickness. The tape should be wrapped in a clockwise direction starting at the first or second full thread. Overlap each wrap by 1/2 the width of the tape. The wrap should be applied with sufficient tension to allow the threads of a single wrapped area to show through without cutting the tape. The wrap should continue for the full effective length of the thread. Pipe sizes 2" and greater will not benefit with more than a second wrap, due to the greater thread depth. To provide a leak proof joint, the pipe should be threaded into the end connection "hand tight". Using a strap wrench only. (Never use a stillson type wrench) tighten the joint an additional 1/2 to 1-1/2 turns past hand tight. Tightening beyond this point may induce excessive stress that could cause failure.

TBM Series Ball Valves

Operating, Installation, and Maintenance Instructions

FLANGED CONNECTION:

Flange bolts should be tight enough to slightly compress the gasket and make a good seal, without distorting or putting excessive stress on the flanges. Suitable washers should be used between the bolt head and flange and the nut and flange. Bolts should be tightened in alternating sequence.

RECOMMENDED FLANGE BOLT TORQUE

VALVE SIZE	# BOLTS	BOLT DIA.	NUT HEIGHT	NUT WIDTH	WASHER THICKNESS	TORQUE FT. LBS.
1/2"	4	1/2"	5/16"	3/4"	.05 to .079	10-15
3/4"	4	1/2"	5/16"	3/4"	.05 to .079	10-15
1"	4	1/2"	5/16"	3/4"	.05 to .079	10-15
1 1/4"	4	1/2"	5/16"	3/4"	.05 to .080	10-15
1 1/2"	4	1/2"	5/16"	3/4"	.05 to .079	10-15
2"	4	5/8"	3/8"	15/16"	.05 to .079	15-25
2 1/2"	4	5/8"	3/8"	15/16"	.05 to .079	20-25
3"	4	5/8"	3/8"	15/16"	.05 to .079	20-25
4"	8	5/8"	3/8"	15/16"	.05 to .079	20-25
6"	8	3/4"	1/2"	1-1/8"	.08 to .099	30-40

RECOMMENDED FLANGE BOLT TORQUE SEQUENCE

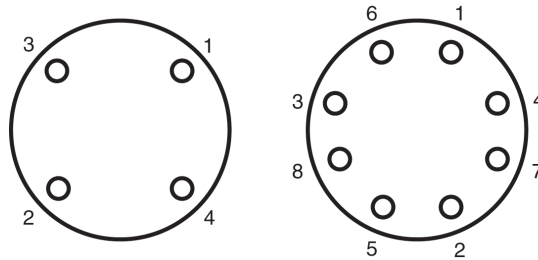

NOTE: USE WELL LUBRICATED METAL BOLTS AND NUTS. USE SOFT RUBBER GASKETS.

NOTE: DUE TO THE DESIGN OF THE VG SERIES DIAPHRAGM VALVES, SIMTECH RECOMENDS THE USE OF LOW PROFILE NUT(JAM NUTS)

TBM Series Ball Valves

Operating, Installation, and Maintenance Instructions

Adjustment/Replacing Seals For VL:Series True Union 3-Way Ball Valve

SIMTECH RECOMMENDS EXTREME CAUTION MUST BE TAKEN WHEN WORKING ON THIS VALVE THE PIPING SYSTEM MUST BE DEPRESSURIZED AND DRAINED PROPER CARE MUST BE TAKEN CONSULT M.S.D.S.(MATERIAL SAFETY DATA SHEETS) INFORMATION REGARDING YOUR SPECIFIC APPLICATION AND MEDIA.

Disassembly of TBM: Series Valve

1. Remove the Union nut and end connector from the body, or the complete valve body from the piping system. Position the valve in the "Closed" position.
2. Using the handle, remove the carrier from the body turning it counter clockwise.
3. From the other end of the valve body apply pressure to the ball. This will force the ball from the body.
4. From the top of stem apply pressure forcing the stem through the body and out.

Replacement of Seal Kit

The o-rings and seals are now accessible for replacement using a "seal" repair kit. Carefully remove the o-rings from their respective locations taking care not to scratch their sealing surfaces. Use a non-petroleum base lubricant to lubricate the o-rings, and re-assemble the valve.

- | | |
|-----------------------|----------------------------------|
| 1. Handle L or T | 9. Thrust collar |
| 2. O-Ring | 10. O-Ring |
| 3. Shaft | 11. Connection |
| 4. Body | 12. Union nut |
| 5. Ball L or T | 13. Spring loaded locking sleeve |
| 6. Ball seating joint | 21. Spigot |
| 7. O-Ring | 22. Screw |
| 8. O-Ring | 23. Cover for screw |

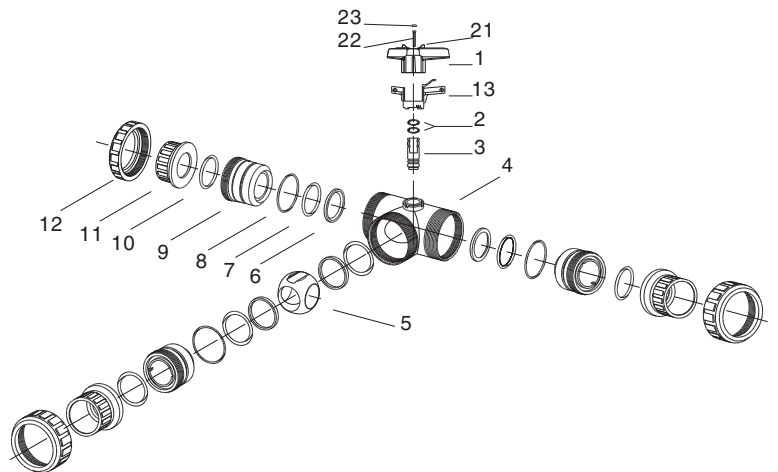

The o-rings and seals are now accessible for replacement using a "seal" repair kit. Carefully remove the o-rings from their respective locations taking care not to scratch their sealing surfaces.

Adjustment of Union Nut

The Union nut (12) should be installed on the valve "hand tight". Using a strap wrench only the joint may be tightened 1/2 to 3/4 of a turn past hand tight.

The following is a list of replacement parts.

- 2. Stem O-ring (2)
- 6. PTFE Seat (3)
- 7. Carrier O-ring (1)
- 8. Seat O-ring (3)
- 10. Union O-ring (3)
- 11. Handle (1)

Note: Items 2, 6, 7, 8 and 10 are supplied as a kit. Individual part cannot be purchased.

VL Series Ball Valves
Operating, Installation, and Maintenance Instructions
NOTES

TBM Series Ball Valves
Operating, Installation, and Maintenance Instructions
NOTES

TBM Series Ball Valves

Operating, Installation, and Maintenance Instructions

Simtech Industrial Products, Inc.

47-A Runway Road, Levittown, PA 19057
Phone: 215-547-0444 Fax: 215-547-9129
E-mail: info@SimtechUSA.com
Web site: www.SimtechUSA.com

WARRANTY

Simtech Industrial Products, Inc. products are warranted to be free from defects in materials and workmanship for one (1) year from date of shipment. No claim shall be permitted under this warranty unless Buyer gives Simtech Industrial Products, Inc. written notice of all respects in which Buyer claims the product to be defective. Notice must be received within ten (10) days from the date which the Buyer discovers, or should have discovered the defect. Buyer shall give Simtech Industrial Products, Inc. a reasonable opportunity to inspect the product after notice has been given. This warranty shall not apply to any products or components, which have been subjected to abnormal use, negligence or accident.

Seller's sole obligation under this warranty shall be limited solely on the repair or replacement, as elected by Simtech Industrial Products, Inc., of defective or nonconforming material. To the maximum extent permitted by law, Buyer irrevocably waives all claims for money damages relating to the condition, use and performance of the goods purchased. In no event shall Simtech Industrial Products, Inc. liability exceed the purchase price of the product sold by Simtech Industrial Products, Inc.

In no event, whether because of a breach of warranty or representation or any other cause, whether based upon contract, tort, warranty or otherwise, arising out of the performance or nonperformance by seller of its obligations under this agreement or with respect to the products sold pursuant here to; shall seller be liable for lost earnings, income or profits or indirect, incidental, liquidated or consequential damages.

The implied warranties of merchantability and fitness for a particular purpose except as set forth in this warranty, express or implied, are hereby disclaimed and excluded. Nothing shall be construed as an additional warranty unless specifically designated as such in writing and signed by Simtech Industrial Products, Inc.

Simtech Industrial Products, Inc. reserves the right, in its discretion, at any time and from time to time, to make changes to any specification, data or information contained herein.