

MATERIAL:
303 Stainless Steel

PHONE: 516.328.3300 • FAX: 516.326.8827 • WWW.SDP-SI.COM

Available on special order:
Hubs assembled to gears or
dials, and passivation.

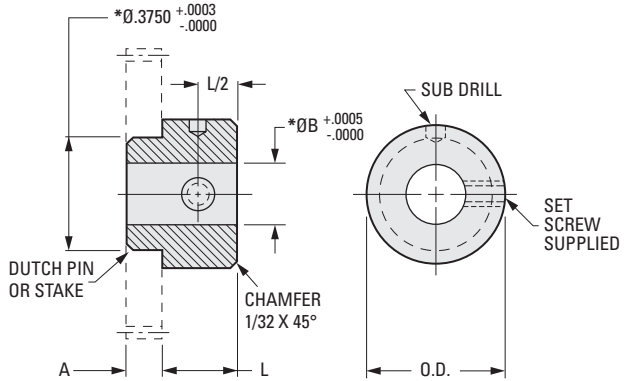
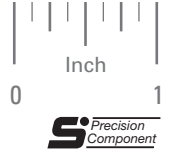

*Diameters Concentric within .0003 T.I.R.

INCH COMPONENT

Catalog Number	A	B Bore	L	O.D.	Set Screw
S2006Y-125078	.125	.0781	.22	7/16	#2-56
S2006Y-125090	.125	.0900	.22	7/16	#2-56
S2006Y-062094	.062	.0937	.22	7/16	#2-56
S2006Y-125094	.125	.0937	.22	7/16	#2-56
S2006Y-062120	.062	.1200	.22	7/16	#2-56
S2006Y-125120	.125	.1200	.22	7/16	#2-56
S2006Y-062125	.062	.1248	.22	7/16	#2-56
S2006Y-125125	.125	.1248	.22	7/16	#2-56
S2006Y-062156	.062	.1562	.22	7/16	#2-56
S2006Y-125156	.125	.1562	.22	7/16	#2-56
S2006Y-062187	.062	.1873	.22	7/16	#4-40
S2006Y-125187	.125	.1873	.22	7/16	#4-40
S2006Y-062241	.062	.2405	.25	1/2	#6-32
S2006Y-125241	.125	.2405	.25	1/2	#6-32
S2006Y-062250	.062	.2498	.25	1/2	#6-32
S2006Y-125250	.125	.2498	.25	1/2	#6-32