

AGMA 10
1/8 FACE
3/16 BORE
20° PRESSURE ANGLE

PHONE: 516.328.3300 • FAX: 516.326.8827 • WWW.SDP-SI.COM

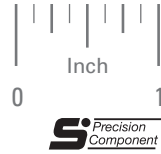

> MATERIAL:

- 303 Stainless Steel
- 2024 Aluminum, Anodized
- T4 or T351 Aluminum Alloy, Anodized before cutting

Available on special order:
14-1/2° P.A., teeth not listed, different bore size and/or material, passivation for Stainless Steel.

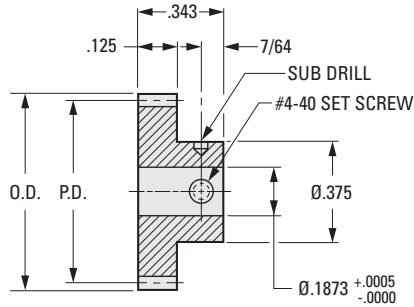
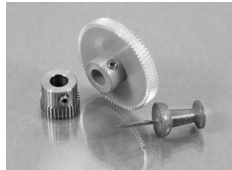
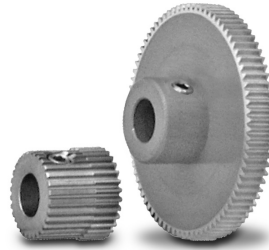

INCH COMPONENT

Catalog Number		No. of Teeth	P.D.	O.D.
303 Stainless Steel	2024 Aluminum Anodized			
S1064Z-080S025	S1064Z-080A025	25 Δ	.3125	.338
S1064Z-080S026	S1064Z-080A026	26 Δ	.3250	.350
S1064Z-080S027	S1064Z-080A027	27 Δ	.3375	.363
S1064Z-080S028	S1064Z-080A028	28 Δ	.3500	.375
S1064Z-080S030	S1064Z-080A030	30 Δ	.3750	.400
S1064Z-080S032	S1064Z-080A032	32	.4000	.425
S1064Z-080S036	S1064Z-080A036	36	.4500	.475
S1064Z-080S040	S1064Z-080A040	40	.5000	.525
S1064Z-080S045	S1064Z-080A045	45	.5625	.588
S1064Z-080S050	S1064Z-080A050	50	.6250	.650
S1064Z-080S055	S1064Z-080A055	55	.6875	.713
S1064Z-080S060	S1064Z-080A060	60	.7500	.775
S1064Z-080S065	S1064Z-080A065	65	.8125	.838
S1064Z-080S070	S1064Z-080A070	70	.8750	.900
S1064Z-080S075	S1064Z-080A075	75	.9375	.963
S1064Z-080S080	S1064Z-080A080	80	1.0000	1.025
S1064Z-080S085	S1064Z-080A085	85	1.0625	1.088
S1064Z-080S090	S1064Z-080A090	90	1.1250	1.150
S1064Z-080S100	S1064Z-080A100	100	1.2500	1.275
S1064Z-080S110	S1064Z-080A110	110	1.3750	1.400
S1064Z-080S120	S1064Z-080A120	120	1.5000	1.525

Δ Hob cuts into hub. Hub diameter never exceeds gear O.D.

- I
- R
- T
- 1
- 2
- 3
- 4
- 5
- 6
- 7
- 8
- 9
- 10
- 11
- 12
- 13
- 14
- 15
- 16